

**WESTERN KENTUCKY UNIVERSITY**  
**OGDEN COLLEGE OF SCIENCE & ENGINEERING**



**WKU**<sup>®</sup>

**DEPARTMENT OF ENGINEERING**  
**CIVIL ENGINEERING PROGRAM**

**CE STUDENT HANDBOOK**  
**EFFECTIVE: 2011-2012**

**WKU/UK** JOINT BACHELOR OF SCIENCE  
PROGRAM IN CIVIL ENGINEERING

# TABLE OF CONTENTS

Overview .....	2
Mission Statement .....	3
Program Objectives .....	4
Program Outcomes .....	5
Plan of Study .....	6
CE Curriculum Flowchart with Prerequisites and Corequisites .....	7
Academic Standards of <b>WKU/UK</b> Joint CE Program .....	8
Degree Requirements .....	10
<b>WKU/UK</b> Joint Program 16 Credit Hours Requirement .....	11
Two (2) Course Sequence Requirement .....	12
Grade of “C” or Better Requirement .....	13
Prerequisites and Corequisites.....	14
Scholarships .....	16
Transfer Students .....	18
Second Degree Seeking Students.....	19
<b>UK</b> University Scholars Combined BS-MS Program* .....	20
<b>WKU</b> CET Graduates Enrolling in the <b>WKU/UK</b> Joint CE Program .....	21
Typical CE Technical Elective Offerings .....	22
Reference Numbers for Pre-Major, Major, Minors, and Certificate Programs .....	23
Land Surveying Programs .....	25
Certificate in Land Surveying Requirements .....	25
Minor in Land Surveying Requirements .....	27
Floodplain Management Program .....	28
Minor in Floodplain Management Requirements .....	29
Worksheets and Forms:	
CE Advising Worksheet (Option 1) .....	30
CE Advising Worksheet (Option 2) .....	31
Academic Standards Appeal Form .....	32

\*This agreement is currently under development. A tentative effective date is for Fall 2012.

## OVERVIEW

Welcome to the Civil Engineering (CE) program. The faculty have assembled this handbook (CE Student Handbook) to familiarize each student with the policies and standards associated with this program. This handbook will be periodically updated, so check the engineering home page at [www.wku.edu/engineering](http://www.wku.edu/engineering) for the latest edition. Although this handbook is as accurate as we can make it, the WKU Catalog is the final authority on policies and procedures. However, the policies and procedures specific to the CE program are discussed in detail in this handbook and are only summarized in the WKU Catalog. Copies of the official WKU Catalog are available in the Registrar's Office in Potter Hall and on the website at [www.wku.edu](http://www.wku.edu).

The **WKU/UK** joint Civil Engineering program is a collaboration between Western Kentucky University (WKU) and the University of Kentucky (UK) leading to a Bachelor of Science degree in Civil Engineering. Students in this program are considered students of both institutions by the joint program. The names of both institutions appear on the Bachelor of Science degree. Although students do not have to go to Lexington, Kentucky to take any of the courses, students are required to have at least 16 credit hours in the major taught by UK faculty. Thus, it is important that students meet with their faculty advisor to monitor progress towards this requirement and the other academic requirements discussed herein.

***For more information contact:***

Shane M. Palmquist, Ph.D., P.E.  
Associate Professor  
Civil Engineering Coordinator  
Department of Engineering  
Western Kentucky University  
270-745-2919  
[shane.palmquist@wku.edu](mailto:shane.palmquist@wku.edu)

## MISSION STATEMENT

The mission of the civil engineering program is to prepare students for professional engineering and management positions in all phases of civil engineering projects. The program provides a broad educational background with a foundation in basic engineering and business principles. These basic skills are complemented by advanced topics in engineering design, management, finance, computer applications, and real world civil engineering experiences throughout the Baccalaureate Degree program.

The civil engineering program fulfills the overall mission of the department of engineering and also meets the following goals:

- Understanding of fundamental engineering concepts that nurture problem solving abilities.
- Knowledge of basic civil engineering skills to prepare graduates for immediate productivity upon graduation.
- A background in management skills as they relate to working with financial matters as well as with people from diverse backgrounds.
- The ability to communicate ideas, processes, and designs effectively.

The teaching philosophy of this program focuses on project based learning. This is achieved by placing competent, practicing engineers in the classroom as professors, engaging students in the practice of civil engineering through hands-on class projects, and involving students in faculty consulting and applied research activities. Real engineering projects often serve as class projects. Project sites and professional engineering and construction management firm offices often serve as classrooms.

## PROGRAM OBJECTIVES

These Program Objectives are intended to be a concise description of what our graduates actually do in their practice 3-5 years after graduation. We will be surveying our graduates on a regular basis to ensure these Objectives are a realistic description of their activities and to determine the graduates' level of preparation for these activities.

- **The graduates of the civil engineering program are technically competent.**

They will possess a broad knowledge of the principles and fundamentals of civil engineering and their application, and thus be able to: successfully practice as professional civil engineers; pursue graduate or professional degrees; or engage in other professional careers that involve the application of the engineering method.

- **The graduates of the civil engineering program are effective team members.**

They will function effectively in multicultural and multidisciplinary groups in their practice of the civil engineering profession. They will effectively participate in the management of projects and the business of which they are a part.

- **The graduates of the civil engineering program are professional.**

They will perform all of their duties professionally and ethically. They will understand that what they do is a part of a larger society and will understand their part within that society. They will engage in life-long learning to continually provide themselves with the necessary skills, certifications, and licenses to effectively perform their professional duties, even if their career takes them beyond engineering and into another profession.

## PROGRAM OUTCOMES

The Program Outcomes describe what students are able to do at graduation.

- **Outcome a**  
Civil engineering seniors will have the ability to apply knowledge of mathematics, science, and engineering.
- **Outcome b**  
Civil engineering seniors will have the ability to design and conduct experiments, as well as to analyze and interpret data.
- **Outcome c**  
Civil engineering seniors will have the ability to design a system, component, or process to meet desired needs. The design will include consideration of both technical and non-technical issues. The design will also include consideration and implementation of the applicable standards and constraints.
- **Outcome d**  
Civil engineering seniors will have the ability to function on multi-disciplinary teams including effective participation in the management of the team project.
- **Outcome e**  
Civil engineering seniors will have the ability to identify, formulate, and solve engineering problems.
- **Outcome f**  
Civil engineering seniors will have an understanding of professional and ethical responsibility.
- **Outcome g**  
Civil engineering seniors will have an ability to communicate effectively.
- **Outcome h**  
Civil engineering seniors will have the broad education necessary to understand the impact of engineering solutions in a global and societal context.
- **Outcome i**  
Civil engineering seniors will recognize the need for, and an ability to engage in life-long learning.
- **Outcome j**  
Civil engineering seniors will have knowledge of contemporary issues.
- **Outcome k**  
Civil engineering seniors will have an ability to use the techniques, skills, and modern engineering tools necessary for engineering practice.

## PLAN OF STUDY

### WKU/UK Joint Bachelor of Science Degree in Civil Engineering

(Revised: 17 September 2010)

This form is a template for completing the degree in eight semesters. If you get off sequence or you cannot take the full load for a given semester, make sure you work with your advisor to select the appropriate courses to minimize prerequisite problems in later semesters. At least 16 credit hours in major must be taught by UK faculty. See “WKU/UK JOINT PROGRAM 16 CREDIT HOURS REQUIREMENT.”

<p><b><u>Semester 1</u></b></p> <p>ENGR 175      Univ Experience – ENGR      1            CE 176        CE Freshman Design            1            AMS 163      Architectural Drafting        3            MATH 136     Calculus I                        4            GEOL 111/113    The Earth and Lab            3/1            Category E     World Cultures Elective      <u>3</u>  <b>16</b></p>	<p><b><u>Semester 2</u></b></p> <p>CE 160/161      Surveying I and Lab            3/1            MATH 137        Calculus II                        4            PHYS 255/256    Physics I and Lab               4/1            ENG 100         Freshman English               3            COMM 161 or 145    Public Speaking                <u>3</u>  <b>19</b></p>
<p><b><u>Semester 3</u></b></p> <p>CE 303/304      Construction Mgt and Lab    3/1            EM 221 or 222    Statics                            3            MATH 237        Multivariable Calculus        4            CHEM 120/121    College Chemistry I &amp; Lab    4/1            Category F       Health and Wellness Elect    <u>1</u>  <b>17</b></p>	<p><b><u>Semester 4</u></b></p> <p>EM 302 or 303    Mechanics of Deform Solids    3            CE 310            Strength of Materials Lab      1            MATH 331        Differential Equations         3            PHYS 265/266    Physics II and Lab              4/1            Category A-II    Foreign Language (102)        3            ENG 200         Intro to Literature              <u>3</u>  <b>18</b></p>
<p><b><u>Semester 5</u></b></p> <p>CE 382 or 373    Structural Analysis            3            CE 410/411      Soil Mechanics and Lab        3/1            CE 341            UK-Fluid Thermal Science     4            CE 370/371      Materials of Constr and Lab    2/1            STAT 301        Probability and Statistics      3            Category F       Health and Wellness Elect      <u>1</u>  <b>18</b></p>	<p><b><u>Semester 6</u></b></p> <p>CE 316            Equipment and Methods        3            CE 331            UK-Transportation Engineering 3            ENG 300         Junior English                  3            CE 412            Foundation Engineering        3            CE 384            Reinforced Concrete Design<sup>1</sup>    3            CE                Technical Elective<sup>2</sup>            <u>3</u>  <b>18</b></p>
<p><b><u>Semester 7</u></b></p> <p>CE 351 or 352    Intro Environmental Eng        3            CE                Technical Elective<sup>2</sup>            3            CE 400            Senior Design Seminar        1            ECON 202        Economics (Micro)             3            HIST 119 or 120    Western Civilization            3            Category B-II    Humanities Elective            <u>3</u>  <b>16</b></p>	<p><b><u>Semester 8</u></b></p> <p>CE 461            Hydrology                        3            CE                Technical Elective<sup>2</sup>            3            CE 498            Senior Project                  3            Category B-II    Humanities Elective            3            Category C        Social and Behavior Sc Elect    <u>3</u>  <b>15</b></p>

**Total Hours = 137**

**NOTES:**

1. Instead of CE 384 Reinforced Concrete Design, students may take CE 482 Elementary Structural Design or CE 483 UK-Elementary Structural Design if offered.
2. A two (2) course sequence in four different civil engineering areas is required. The curriculum already includes a two (2) course sequence in structures, geotechnical engineering, and construction. Therefore, each student must select one of their technical electives to cover an additional area such as surveying, materials, environmental engineering, hydrology, or transportation. See “TWO (2) COURSE SEQUENCE REQUIREMENT.”

## CE CURRICULUM FLOWCHART WITH PREREQUISITES AND COREQUISITES

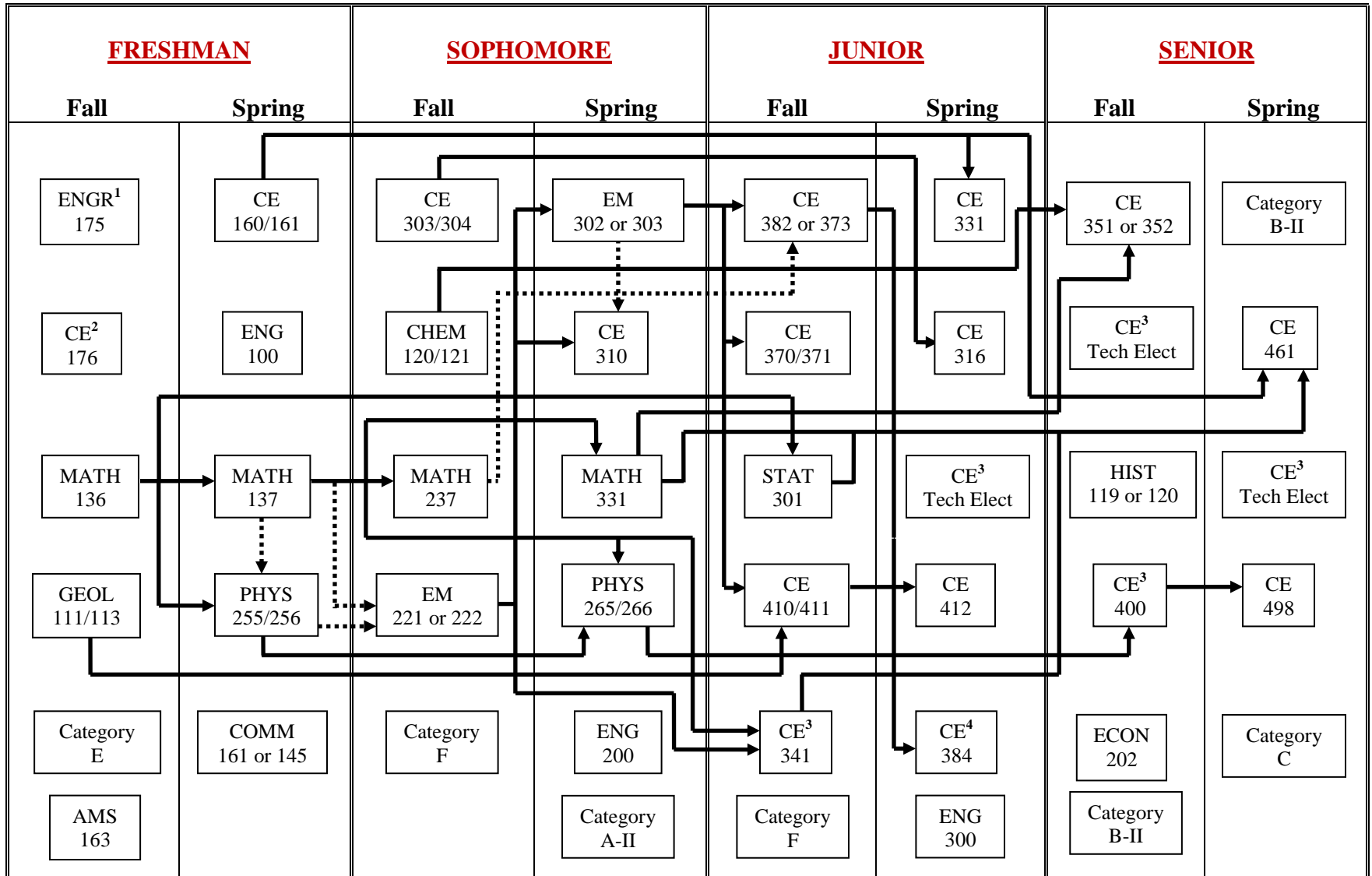

—————> Indicates prerequisite course

.....> Indicates corequisite course

- Notes: 1. Corequisite is MATH 116 or higher.  
2. Corequisite is MATH 117 or higher.

3. See "PREREQUISITES AND COREQUISITES".  
4. If offered, students may take CE 482 or 483.

# ACADEMIC STANDARDS OF WKU/UK JOINT CE PROGRAM

## Admission to Western Kentucky University

1. Students are admitted to WKU under the institutional standard, which currently requires completion of the pre-college curriculum, a minimum GPA of 2.5 of a 4.0 scale, and a minimum composite ACT of 20/930 Total SAT.
2. Students are not immediately admitted directly into any major of the university. If a student expresses an interest in a specific major, then that student is assigned an advisor from that area and is placed in a section of our university introductory course, ENGR 175 Freshman Experience.
3. Students are identified as a pre-major until specified courses are completed as shown below in the following section. Additional civil engineering programmatic requirements are given in the section, "Graduation Requirements," page 9.
4. Students are expected to meet all of the pre-major requirements within the first 48 hours of degree credit and are expected to change their status from pre-major to major in civil engineering.

## Eligibility to Change from Pre-Major to Major Status

In order to transition from pre-major to major in civil engineering, students must complete each of the following courses and labs with a grade of "C" or better:

### Communication

ENG 100	College Writing	3 hrs
COMM 145 or 161	Public/Business Speaking	3 hrs
AMS 163	Architectural Drafting	3 hrs

### Mathematics

MATH 136	Calculus I	4 hrs
MATH 137	Calculus II	4 hrs

### Science

Physics 255 and 256	University Physics I and Lab	4/1 hrs
CHEM 120 and 121	College Chemistry I and Lab	4/1 hrs

### Engineering

CE 176	Civil Engineering Freshman Design	1 hr
CE 160 and 161	Principles of Surveying and Lab	3/1 hrs
EM 221 or 222	Statics	3 hrs

**Total Hours = 35 hrs**

Check iCAP for progress towards meeting this requirement. To enroll in CE 341 or 342 Fluid Thermal Science, students must have major status in civil engineering and MATH 137 Calculus II and EM 221 or 222 Statics as prerequisite courses. To see this requirement visually in a semester by semester format, see "Pre-Major to Major Table" on the next page.

## ACADEMIC STANDARDS OF WKU/UK JOINT CE PROGRAM

To transition from pre-major to major in civil engineering, students must complete the following courses marked in yellow in the table below with a grade of “C” or better in each course/lab.

### Pre-Major to Major Table

<b><u>Semester 1</u></b>			<b><u>Semester 2</u></b>		
ENGR 175	Univ Experience – ENGR	1	CE 160/161	Surveying I and Lab	3/1
CE 176	CE Freshman Design	1	MATH 137	Calculus II	4
AMS 163	Architectural Drafting	3	MATH 137	Physics I and Lab	4/1
MATH 136	Calculus I	4	ENG 100	Freshman English	3
GEOL 111/113	The Earth and Lab	3/1	COMM 161 or 145	Public Speaking	<u>3</u>
Category E	World Cultures Elective	<u>3</u>			<b>19</b>
		<b>16</b>			
<b><u>Semester 3</u></b>			<b><u>Semester 4</u></b>		
CE 303/304	Construction Mgt and Lab	3	EM 302 or 303	Mechanics of Deform Solids	3
EM 221 or 222	Statics	3	CE 310	Strength of Materials Lab	1
MATH 237	Multivariable Calculus	4	MATH 331	Differential Equations	3
CHEM 120/121	College Chemistry I & Lab	4/1	PHYS 265/266	Physics II and Lab	4/1
Category F	Health and Wellness Elect	<u>1</u>	Category A-II	Foreign Language (102)	3
		<b>17</b>	ENG 200	Intro to Literature	<u>3</u>
					<b>18</b>
<b><u>Semester 5</u></b>			<b><u>Semester 6</u></b>		
CE 382 or 373	Structural Analysis	3	CE 316	Equipment and Methods	3
CE 410/411	Soil Mechanics and Lab	3/1	CE 331	UK-Transportation Engineering	3
CE 341	UK-Fluid Thermal Science	4	ENG 300	Junior English	3
CE 370/371	Matls of Constr and Lab	2/1	CE 412	Foundation Engineering	3
STAT 301	Probability and Statistics	3	CE 384	Reinforced Concrete Design	3
Category F	Health and Wellness Elect	<u>1</u>	CE	Technical Elective	<u>3</u>
		<b>18</b>			<b>18</b>
<b><u>Semester 7</u></b>			<b><u>Semester 8</u></b>		
CE 351 or 352	Intro Environmental Eng	3	CE 461	Hydrology	3
CE	Technical Elective	3	CE	Technical Elective	3
CE 400	Senior Design Seminar	1	CE 498	Senior Project	3
ECON 202	Economics (Micro)	3	Category B-II	Humanities Elective	3
HIST 119 or 120	Western Civilization	3	Category C	Social and Behavior Sc Elect	<u>3</u>
Category B-II	Humanities Elective	<u>3</u>			<b>15</b>
		<b>16</b>			

**Total Hours = 137**

### Graduation Requirements

After satisfying the requirements to transition from pre-major to major in civil engineering:

- Students must satisfy the graduation requirements of WKU, including a minimum cumulative GPA of 2.0 in all coursework.
- Students must have a grade of “C” or better in:
  - All CE courses including technical electives (except for one (1) CE 400 level course), and
  - EM 221 or 222: Statics, and EM 302 or 303: Mechanics of Deformable Solids.
- Each student’s transcript must have at least 16 hours of credit in the major taught by a UK faculty member.
- Completion of a two (2) course sequence in four (4) different civil engineering areas. See “TWO (2) COURSE SEQUENCE REQUIREMENT” in the CE Student Handbook.

## DEGREE REQUIREMENTS

This section of the CE Student Handbook covers specific civil engineering requirements of the **WKU/UK** joint degree program in civil engineering. These CE programmatic requirements are as follows:

- **WKU/UK** Joint Program 16 Credit Hours Requirement
- Two (2) Course Sequence Requirement
- Grade of “C” or Better Requirement

These requirements are discussed in detail next.

## **WKU/UK JOINT PROGRAM 16 CREDIT HOURS REQUIREMENT**

Students in the civil engineering program are required to obtain 16 credit hours in the major from University of Kentucky (UK) faculty members. Students must complete a minimum of 16 credit hours from the following list of approved courses:

- EM 221 UK-Statics (3 hr)
- EM 302 UK-Mechanics of Deformable Solids (3 hr)
- EM 313 UK-Dynamics (3 hr)
- CE 341 UK-Fluid and Thermal Science (4 hr)
- CE 373 UK-Structural Analysis (3 hr)
- CE 331 UK-Transportation Engineering (3 hr)
- CE 351 UK-Intro to Environmental Engineering (3hr)
- CE 483 UK-Elementary Structural Design (3 hr)
- CE 490 UK-CE Selected Topics (fall)<sup>†</sup> (3 hr)
- CE 491 UK-CE Selected Topics (spring)<sup>†</sup> (3 hr)

<sup>†</sup>May be taken more than once provided the topic is different.

Students may choose to take summer course(s) at the University of Kentucky for progress toward completion of this requirement from the above list of courses or CE course(s) or technical elective course(s) from the WKU/UK degree program. See “PLAN OF STUDY.”

## TWO (2) COURSE SEQUENCE REQUIREMENT

Each student is required to have a two (2) course sequence in four different civil engineering areas. The required courses already include a two (2) course sequence in structures, geotechnical engineering, and construction. Therefore, each student must select one of their technical electives to cover an additional area such as surveying, materials, environmental engineering, hydrology, or transportation.

The three (3) two course sequences already included in the civil engineering curriculum are:

- **Structures**
  - (1) CE 382 Structural Analysis or CE 373 UK-Structural Analysis, and
  - (2) CE 384 Reinforced Concrete Design or CE 482 Elementary Structural Design or CE 483 UK-Elementary Structural Design
- **Geotechnical Engineering**
  - (1) CE 410/411 Soils Mechanics and Lab, and
  - (2) CE 412 Foundation Engineering
- **Construction**
  - (1) CE 303/304 Construction Management and Lab, and
  - (2) CE 316 Equipment & Methods

One (1) additional two course sequence from the following civil engineering areas is required:

- **Surveying**
  - (1) CE 160 Principles of Surveying and Lab, and
  - (2) CE 378/379 Route Surveying and Lab or CE 380/381 Boundary Surveying and Lab
- **Materials**
  - (1) CE 370/371 Construction Materials and Lab, and
  - (2) CE 426 Advanced Construction Materials
- **Environmental Engineering**
  - (1) CE 351 or 352 Introduction to Environmental Engineering, and
  - (2) CE 491 UK-Selected Topics (Topic: Water and Wastewater Treatment)
- **Hydrology**
  - (1) CE 461 Hydrology, and
  - (2) CE 462 Hydraulic Engineering or CE 300 Floodplain Management
- **Transportation**
  - (1) CE 331 Transportation Engineering, and
  - (2) CE 490 UK-Selected Topics (Topic: Pavement Design)

Note, other options for completing this requirement are possible with permission.

## GRADE OF “C” OR BETTER REQUIREMENT

See the semester by semester plan of study table below, which shows the minimum grade for each course needed for completion without repeat. Each course shown below with a “C” in the table denotes “C” or better. A grade of “C” or better is required in all CE courses. For degree completion, CE students will take many 400 level senior courses. A grade of “D” is permitted in a single (1) 400 level senior course only. All other CE courses require a grade of “C” or better. While the table below shows the minimum acceptable grade in each course, two additional requirements are:

- Students must complete a list of pre-major courses with a grade of “C” or better in each course/lab. See section “Eligibility to Change from Pre-Major to Major Status” in the Joint [WKU/UK](#) CE Program under “ACADEMIC STANDARDS OF [WKU/UK](#) JOINT CE PROGRAM.”
- Students must satisfy the graduation requirements of Western Kentucky University (see WKU Catalog), including a minimum GPA of 2.0 in all coursework.

<b><u>Semester 1</u></b> ENGR 175      Univ Experience - ENGR      D CE 176          CE Freshman Design            C AMS 163        Architectural Drafting           C MATH 136       Calculus I                            C GEOL 111/113   The Earth and Lab                D/D Category E      World Cultures Elective        D			<b><u>Semester 2</u></b> CE 160/161      Surveying I and Lab            C/C MATH 137        Calculus II                          C PHYS 255/256   Physics I and Lab                C/C ENG 100          Freshman English                C COMM 161 or 145   Public Speaking                C		
<b><u>Semester 3</u></b> CE 303           Construction Mgt and Lab      C/C EM 221 or 222   Statics                                C MATH 237        Multivariable Calculus        D CHEM 120/121   College Chem I and Lab        C/C Category F      Health and Wellness Elect    D			<b><u>Semester 4</u></b> EM 302 or 303   Mech of Deform Solids        C CE 310           Strength of Materials Lab      C MATH 331        Differential Equations         D PHYS 265/266   Physics II and Lab              D/D Category A-II    Foreign Language (102)      D ENG 200          Intro to Literature               D		
<b><u>Semester 5</u></b> CE 382 or 373    Structural Analysis              C CE 410/411      Soil Mechanics and Lab        C CE 341           UK-Fluid Thermal Sc          C CE 370/371      Matls of Constr and Lab       C/C STAT 301        Probability and Statistics      D Category F      Health and Wellness Elect    C			<b><u>Semester 6</u></b> CE 316           Equipment and Methods        C CE 331           Transportation Engineering    C ENG 300         Junior English                    D CE 412           Foundation Engineering        C CE 384           Reinforced Concrete Design    Note 1 CE                Technical Elective                Note 2		
<b><u>Semester 7</u></b> CE 351 or 352    Intro Environmental Eng        C CE                Technical Elective                Note 2 CE 400           Senior Design Seminar        C ECON 202        Economics (Micro)              D HIST 119 or 120   Western Civilization            D Category B-II    Humanities Elective            D			<b><u>Semester 8</u></b> CE 461           Hydrology                          Note 2 CE                Technical Elective                Note 2 CE 498           Senior Project                    C Category B-II    Humanities Elective            D Category C      Social and Behav Sc Elect     D		

### NOTES:

1. A grade of “C” or better is required in CE 384 Reinforced Concrete Design. If CE 482 Elementary Structural Design or CE 483 UK-Elementary Structural Design is taken, a grade of “D” in one CE 400 level senior course is permitted.
2. A grade of “C” or better is required. However, a grade of “D” in one CE 400 level senior course is permitted.

## PREREQUISITES AND COREQUISITES

### Civil Engineering Courses:

<u>Course</u>	<u>Prerequisites</u>	<u>Corequisites</u>
ENGR 175 University Experience – Engineering	Students or transfer students with fewer than 24 credit hours	MATH 116 or higher
CE 176 CE Freshman Design	Transfer or change of major students who have earned at least 24 semester hours of credit or have completed a course equivalent to the generic WKU University Experience, or permission of instructor	MATH 117 or higher
CE 160 Principles of Surveying	High school algebra and trigonometry	CE 161
CE 161 Principles of Surveying I Lab	none	CE 160
CE 300 Floodplain Management	Junior standing or approval of instructor	none
CE 303 Construction Management	none	CE 304
CE 304 Construction Management Lab	none	CE 303
CE 310 Strengths of Materials Lab	MATH 137 and EM 221 or 222	EM 302 or 303
CE 316 Equipment & Methods	CE 303	none
CE 326 Engineering Law	none	none
CE 331 UK-Transportation Engineering	CE 160 and 161	none
CE 332 Transportation Engineering	CE 160 and 161	none
CE 341 UK-Fluid and Thermal Science	MATH 137, EM 221 or 222, and major status in civil engineering	none
CE 342 Fluid and Thermal Science	MATH 137, EM 221 or 222, and major status in civil engineering	none
CE 351 UK-Intro to Environmental Engineering	MATH 331 and CHEM 120	none
CE 352 Intro to Environmental Engineering	MATH 331 and CHEM 120	none
CE 360 Estimating, Scheduling, Bidding	CE 303	CE 361
CE 361 Estimating Lab	CE 303	CE 360
CE 370 Materials of Construction	EM 302 or 303	CE 371
CE 371 Materials of Construction Lab	none	CE 370
CE 373 UK-Structural Analysis	EM 302 or 303	MATH 237
CE 378 Route Surveying	CE 160/161 and AMS 163	CE 379
CE 379 Route Surveying Lab	none	CE 378
CE 380 Boundary Surveying	CE 160/161 and AMS 163	CE 381
CE 381 Boundary Surveying Lab	none	CE 380
CE 382 Structural Analysis	EM 302 or 303	MATH 237
CE 383 Structural Steel Design	CE 382 or 373	none
CE 384 Reinforced Concrete Design	CE 382 or 373	none
CE 400 Civil Engineering Senior Design Seminar	PHYS 265 and senior standing, or consent of instructor	CE 498 next semester
CE 410 Soil Mechanics	GEOL 111 and 113, and EM 302 or 303	CE 411
CE 411 Soil Mechanics Lab	none	CE 410
CE 412 Foundation Engineering	CE 410	none
CE 426 Advanced Construction Materials	CE 370	none
CE 436 Design/Construction Integration	Senior standing	none
CE 440 Masonry Design and Construction	CE 382 or 373, and 370 and 371	CE 441
CE 441 Masonry Construction Lab	none	CE 440
CE 444 Bridge Engineering	CE 384 or 482 or 483	none
CE 451 Water and Wastewater Treatment	CE 351 or CE 352	none
CE 461 Hydrology	MATH 331, STAT 301, CE 160, and CE 341 or 342	none
CE 462 Hydraulic Engineering Systems	MATH 331 and CE 461	none
CE 474 Civil Engineering Design Project	Permission of instructor	none
CE 475 Selected Topics in Civil Engineering	Permission of instructor	none
CE 476 Highway Construction	CE 370	none
CE 482 Elementary Structural Design	CE 382 or 373	none
CE 483 UK-Elementary Structural Design	CE 382 or 373	none
CE 486 Steel & Concrete Construction	CE 316	none

## PREQUISITES AND COREQUISITES

### Civil Engineering Courses (continued):

<u>Course</u>	<u>Prerequisites</u>	<u>Corequisites</u>
CE 490 UK-CE Selected Topics (Fall)	Permission of instructor	none
CE 491 UK-CE Selected Topics (Spring)	Permission of instructor	none
CE 498 Senior Design Project	CE 400	none

### Engineering Mechanics, Math, and Science Courses:

<u>Course</u>	<u>Prerequisites</u>	<u>Corequisites</u>
EM 221 UK-Statics	MATH 136	MATH 137 and PHYS 255
EM 222 Statics	MATH 136	MATH 137 and PHYS 255
EM 302 UK-Mechanics of Deformable Solids	MATH 137, and EM 221 or 222 with C or better	CE 310
EM 303 Mechanics of Deformable Solids	MATH 137, and EM 221 or 222 with C or better	CE 310
MATH 136 Calculus and Analytic Geometry I	4 years of high school math, including: algebra II, geometry, trigonometry, and satisfactory score on placement exam; or MATH 117 with C or better; or MATH 118 with C or better	none
MATH 137 Calculus and Analytic Geometry II	MATH 136 with C or better	none
MATH 237 Multivariable Calculus	MATH 137 with C or better	none
MATH 331 Differential Equations	MATH 137	none
STAT 301 Probability and Applied Statistics	MATH 136 or 142	none
CHEM 120/121 College Chemistry I and Lab	Chemistry placement exam; or CHEM 116 with C or better	MATH 117
PHYS 255/256 University Physics I and Lab	MATH 136 with C or better	MATH 137
PHYS 265/266 University Physics II and Lab	PHYS 255 with C or better and MATH 137 with C or better	none
GEOL 111/113 The Earth and Lab	none	none
AMS 163 Architectural Drafting	High school algebra and trigonometry	none

### Caution when registering for courses with prerequisites:

Students must meet all prerequisites and corequisites to take a course unless special permission is given by the instructor. Students need to be aware of all prerequisites, for example:

- A student may earn a “D” in EM 302 or 303 in the fourth semester. In the fifth semester, the student will be permitted to register and take: CE 373 or 382 Structural Analysis, CE 370/371 Materials of Construction and Lab, and CE 410/411 Soil Mechanics and Lab provided all other prerequisites and corequisites are met. However, prior to graduation, the student will need to repeat EM 302 or 303 and earn a grade of “C” or better.
- A student may earn a “D” in MATH 137 Calculus II. The student based on this grade can go on and take MATH 331 Differential Equations since only the course is listed as a prerequisite. However, the student will not be permitted to take PHYS 265/266 University Physics II and Lab and MATH 237 Multivariable Calculus until a grade of “C” or better has been earned, since this grade is part of the prerequisite requirement.

# SCHOLARSHIPS

There are many scholarship opportunities available at Western Kentucky University and beyond. Below is a partial list of civil engineering related scholarships that are available. Please contact your advisor for more information or visit the links provided below.

## **Kentucky Transportation Cabinet (KTC) Scholarship Program**

- Scholarship program began in 1948 and is the oldest of its kind in the United States.
- Available to full-time incoming freshman and returning students studying civil engineering.
- Stipend award – worth approximately **\$5,000** per semester.
- Summer employment opportunities available.
- Deadline for application – **March 1<sup>st</sup>** each year for the following academic year.
- For more information: [www.transportation.ky.gov/scholarship/](http://www.transportation.ky.gov/scholarship/)

## **Ogden Foundation Scholarships**

- Available to full-time incoming freshman and returning students pursuing a major within Ogden College of Science and Engineering who are Kentucky residents with a high school grade point average (GPA) of 3.2 or higher and have an ACT composite score of 26 or higher (or 26 or higher in math and science).
- Award – **\$750** per semester and is renewable with a GPA of 3.2 or higher.
- Deadline for application – **February 1<sup>st</sup>** each year for the following academic year.
- For more information: [www.wku.edu/ogden/cmsms/index.php?page=scholarships](http://www.wku.edu/ogden/cmsms/index.php?page=scholarships)

## **Boyce D. Tate Scholarship**

- In honor of Prof. Boyce D. Tate who came to WKU in 1965 to develop engineering technology programs.
- Recipient will be designated as the "Boyce D. Tate Scholar" in engineering.
- Available to full-time students that have completed 60 hours of coursework toward a degree in the Engineering Department.
- Award – **\$1,000** per year and is renewable.
- Deadline for application – **March 1<sup>st</sup>** each year for the following academic year.
- For more information, contact Dr. Julie Ellis, Engineering Depart. Head, at 270-745-2461.

## **Kentucky Society of Professional Engineers (KSPE): Mammoth Cave Chapter Scholarship**

- First scholarship awarded in 2011.
- Available to full-time students that have completed 75 hours of coursework toward a degree in the Engineering Department and who have graduated from a high school in the Mammoth Cave KSPE area (Allen, Barren, Edmonson, Grayson, Logan, Metcalfe, Monroe, Simpson, and Warren counties).
- Up to two (2) awards – **\$500** each per year and are renewable.
- Deadline for application – **April 15<sup>th</sup>** each year for the following academic year.
- For more information: [www.kspemammothcave.org](http://www.kspemammothcave.org)

### **American Society of Civil Engineers (ASCE): Kentucky Section Scholarship**

- Available to juniors and seniors who have been active or have held a significant leadership position in the ASCE Student Chapter organization at WKU.
- Award – **\$1,000** per year and is renewable. The scholarship is awarded at the annual meeting of the ASCE Kentucky Section. To receive the scholarship, the student must attend the annual meeting.
- Deadline for application – April 15<sup>th</sup> each year for the following academic year.
- For more information, contact Dr. Shane M. Palmquist at 270-745-2919.

## TRANSFER STUDENTS

Transfer students are strongly encouraged to properly transfer all courses and credits to be counted toward their civil engineering degree within their first semester at WKU. Contact your advisor for more information.

Transfer students enrolling at WKU are eligible to count courses taken at other accredited institutions toward the requirement of 16 credit hours in the major from UK faculty. See “[WKU/UK JOINT PROGRAM 16 CREDIT HOURS REQUIREMENT](#).” Transfer students may receive credit for courses subject to the approval of the civil engineering coordinator of Department of Engineering at WKU and the chairperson of the Civil Engineering Department at UK.

Transfer students with less than 24 credit hours are required to take ENGR 175 University Experience – Engineering (1 credit hour) and CE 176 CE Freshman Design (1 credit hour). Transfer students with 24 credit hours or more are not required to take ENGR 175. These students take CE 176 CE Freshman Design (1 credit hour).

## **SECOND DEGREE SEEKING STUDENTS**

Students seeking to complete a second college degree in civil engineering must complete a Second Degree Program Form. Students are strongly encouraged to complete this form within their first academic year in order to graduate in a timely manner. See your advisor for more information.

## UK UNIVERSITY SCHOLARS COMBINED BS-MS PROGRAM\*

CE students may apply to participate in the UK University Scholar Combined BS-MS Program. This program leads to a Bachelor of Science (BS) degree from WKU/UK and a Master of Science (MSCE) degree from UK. After admission to the combined program, students benefit by the following:

- Up to 6 credit hours of 500-level UK courses taken as an undergraduate in the joint program may count toward his/her MSCE at UK. However, the faculty in these courses must be informed by the student that he/she should be treated as a graduate student for grading purposes.
- The student may be able to complete his/her last semester on the UK campus and take advantage of the 6 credit hour BSCE-MSCE double count.

Students seeking admissions to the UK University Scholar Program may apply for entry to the program after completing at least 100 credit hours of undergraduate study in civil engineering. No less than 30 of these credit hours must be in CE prefix courses. Students must also have an overall undergraduate GPA of not less than 3.2 and a GPA not less than 3.5 for all CE prefix courses at the time of application to the program. Students must also take the Graduate Record Examination (GRE), and the scores must be available prior to entry. Student applicants must have a combined score on the verbal and quantitative portions of the GRE of at least 1,000.

Students admitted into the UK University Scholars Program in Civil Engineering have two options for completing a Master of Science in Civil Engineering (MSCE) degree. These options are:

- **Thesis option:** 24 credit hours of course work plus thesis. The thesis counts as 6 credit hours. This is a research oriented MSCE.
- **Non-thesis option:** 30 credit hours of course work. This is a course oriented MSCE.

### *For more information contact:*

Shane M. Palmquist, Ph.D., P.E.  
Associate Professor  
Civil Engineering Coordinator  
Department of Engineering  
Western Kentucky University  
270-745-2919  
[shane.palmquist@wku.edu](mailto:shane.palmquist@wku.edu)

Kamyar Mahboub, Ph.D., P.E.  
Lawson Professor of Civil Engineering  
Director of Graduate Studies  
Department of Civil & Environmental Engineering  
University of Kentucky  
859-257-4279  
[kmahboub@engr.uky.edu](mailto:kmahboub@engr.uky.edu)

*\*This agreement is currently under development. A tentative effective date is set for **Fall 2012**.*

## WKU CET GRADUATES ENROLLING IN THE WKU/UK JOINT CE PROGRAM

The requirements for graduates of the WKU Civil Engineering Technology (CET) program who want to complete the WKU/UK Joint Civil Engineering Program are given herein. The table below on the right shows the courses the CET graduate will need to complete the B.S. in Civil Engineering at WKU. Since this is considered a second degree from WKU, no general education courses are required. This document was approved by the WKU/UK Joint Faculty Fall 2006.

WKU CET graduates will receive credit for the following courses in the WKU/UK Joint Civil Engineering Program

COURSE	COURSE TITLE	CR
UC 101	Freshman Seminar	2
AMS 163	Architectural Drafting	3
CE 303	Construction Mgmt.	3
GEOL 111/113	The Earth and Lab	3/1
EM 221	Statics	3
CE 160/161	Prin of Surveying & Lab	3/1
CE 310	Strength of Materials Lab	1
CE 370/371	Matls of Construction & Lab	2/1
CE	Technical Elective	3

WKU CET graduates will need to complete the following courses for a degree in the WKU/UK Joint Civil Engineering Program

COURSE	COURSE TITLE	CR
MATH 136	Calculus I	4
MATH 137	Calculus II	4
MATH 237	Multivariable Calculus	4
MATH 331	Differential Equations	3
STAT 301	Probability & Applied Statistics	3
PHYS 255/256	Physics I and Lab	4/1
PHYS 265/266	Physics II and Lab	4/1
CHEM 120/121	College Chemistry I and Lab	4/1
ECON 202	Economics (Micro)	3
EM 302 or 303	Mechanics of Deformable Solids	3
CE 304	Construction Management Lab	1
CE 316	Equipment and Methods	3
CE 331	Transportation Engineering	3
CE 341 or 342	Fluid Thermal Science	4
CE 351 or 352	Intro to Environmental Eng.	3
CE 382 or 373	Structural Analysis	3
CE 384	Reinforced Concrete Design <sup>1</sup>	3
CE 400	Senior Design Seminar	1
CE 410/411	Soils Mechanics and Lab	3/1
CE 412	Foundation Engineering	3
CE 461	Hydrology	3
CE	Technical Elective <sup>2,3</sup>	3
CE	Technical Elective <sup>2,3</sup>	3
CE 498	Senior Project	3

### NOTES:

1. A grade of "C" or better is required in CE 384 Reinforced Concrete Design. If CE 482 Elementary Structural Design or CE 483 UK-Elementary Structural Design is taken, a grade of "D" in one CE 400 level senior course is permitted.
2. Surveying electives from the WKU CET curriculum will count for CE technical electives.
3. A grade of "C" or better is required in all CE courses including technical electives and in EM 302 or 303.

## TYPICAL CE TECHNICAL ELECTIVE OFFERINGS

### Fall

CE 378/379	Route Surveying and Lab	3/1
CE 383	Structural Steel Design	3
CE 444	Bridge Engineering	3
CE 474	Civil Eng Design Project	1-3
CE 475	Selected Topics in CE	3
CE 490	UK-CE Selected Topics	3
EM 313	UK-Dynamics	3

### Spring

CE 300	Floodplain Management	3
CE 380/381	Boundary Surveying and Lab	3/1
CE 475	Selected Topics in CE	3
CE 426	Adv Construction Materials	3
CE 440/441	Masonry Design & Constr & Lab	3/1
CE 474	Civil Engineering Design Project	1-3
CE 475	Selected Topics in Civil Eng	3
CE 491	UK-CE Selected Topics	3
EM 313	UK-Dynamics	3

## **REFERENCE NUMBERS FOR PRE-MAJOR, MAJOR, MINORS, AND CERTIFICATE PROGRAMS**

WKU assigns reference numbers which are used to designate and classify students in the civil engineering program as follows:

- Pre-major in civil engineering      Ref. # **534P**
- Major in civil engineering      Ref. # **534**
- Minor in land surveying      Ref. # **405**
- Minor in floodplain management      Ref. # **361**
- Certificate in land surveying      Ref. # **1700**

## LAND SURVEYING PROGRAMS

### **Certificate in Land Surveying** (Reference Number 1700)

Students or post-graduates wanting to complete the certificate in land surveying generally fall into one of the following two categories:

#### **Category I:**

- Civil engineering undergraduate students who want to pursue licensure as a professional surveyor in the state of Kentucky (15.0 credit hours), OR
- Post-graduates with baccalaureate degrees in civil engineering, mining, or agricultural engineering accredited by the Accreditation Board for Engineering and Technology (ABET) who want to pursue licensure as a professional surveyor in the state of Kentucky (15.0 credit hours).

#### **Category II:**

- Post-graduates with baccalaureate degrees in majors other than civil engineering, mining, or agricultural engineering who want to pursue licensure as a professional surveyor in the state of Kentucky (26.0 credit hours).

### **Minor in Land Surveying** (Reference Number 405)

Students wanting to complete the minor in land surveying must meet one of the following descriptions:

- Civil engineering undergraduate students who want to pursue licensure as a professional surveyor in the state of Kentucky and want to study additional topics in surveying (26.0 credit hours), OR
- Undergraduate students with majors other than civil engineering who want to pursue licensure as a professional surveyor in the state of Kentucky (26.0 credit hours).

#### ***For more information contact:***

Ronald Gallagher, Ph.D., P.E., P.L.S., C.P.G.  
Assistant Professor  
Department of Engineering  
Western Kentucky University  
270-745-2005  
[ronald.gallagher@wku.edu](mailto:ronald.gallagher@wku.edu)

# CERTIFICATE IN LAND SURVEYING REQUIREMENTS

## Option I:

Undergraduate students majoring in civil engineering or post-graduates with a baccalaureate degree in civil engineering, mining, or agricultural engineering accredited by the Accreditation Board for Engineering and Technology (ABET) may obtain a Certificate in Land Surveying in order to pursue licensure as a professional surveyor in the state of Kentucky by completing the following courses (15.0 credit hours):

AMS 163	Architectural Drafting	3.0 Credit hours
CE 160	Principles of Surveying	3.0
CE 161	Principles of Surveying Lab	1.0
CE 378	Route Surveying	3.0
CE 379	Route Surveying Lab	1.0
CE 380	Boundary Surveying	3.0
CE 381	Boundary Surveying Lab	<u>1.0</u>

**TOTAL HOURS: 15.0**

### Prerequisite Flowchart of Required Courses

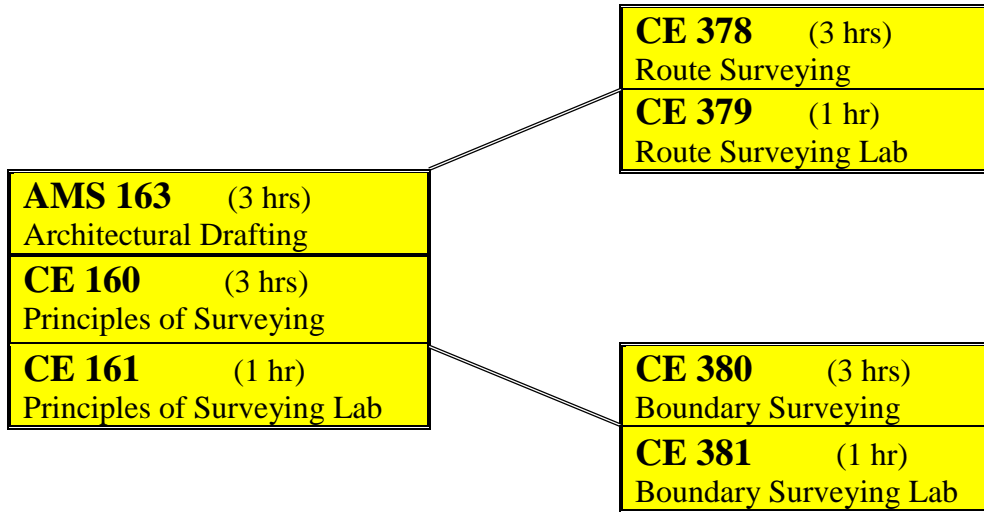

**Option II:**

Post-graduates with baccalaureate degrees in majors other than civil engineering, mining, or agricultural engineering may obtain a Certificate in Land Surveying in order to pursue licensure as a professional surveyor in the state of Kentucky by completing the following courses (26.0 credit hours):

AMS 163	Architectural Drafting	3.0 Credit hours
CE 160	Principles of Surveying	3.0
CE 161	Principles of Surveying Lab	1.0
CE 378	Route Surveying	3.0
CE 379	Route Surveying Lab	1.0
CE 380	Boundary Surveying	3.0
CE 381	Boundary Surveying Lab	1.0
GEOG 316	Fundamentals of GIS	4.0
GEOG 318	GIS for Engineers <sup>†</sup>	3.0
GEOG 414	Remote Sensing Fundamentals	<u>4.0</u>

**TOTAL HOURS: 26.0**

<sup>†</sup>GEOG 317 Geographic Information Systems (3 hours) can be taken instead of GEOG 318 Geographic Information Systems for Engineers.

**Prerequisite Flowchart of Required Courses**

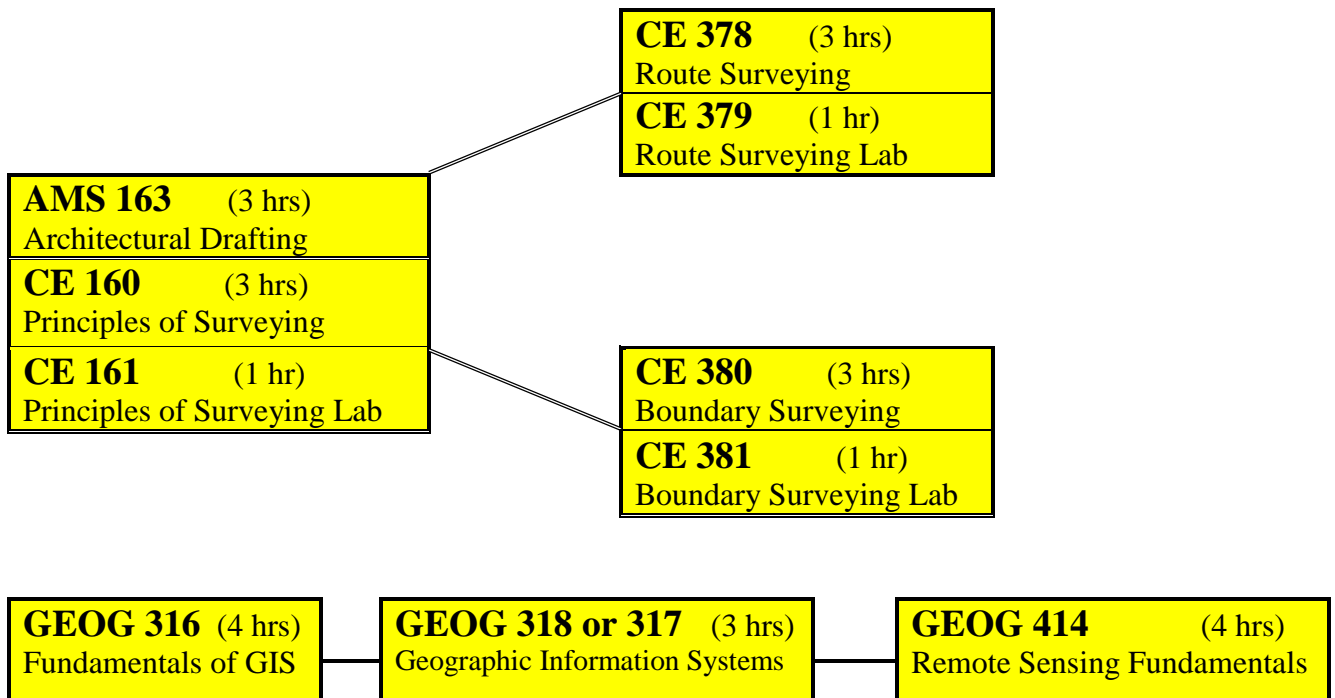

## MINOR IN LAND SURVEYING REQUIREMENTS

Civil engineering undergraduate students who want to pursue licensure as a professional surveyor in the state of Kentucky and want to study additional topics in surveying (26.0 credit hours) must complete the requirements as listed below. Undergraduate students with majors other than civil engineering who want to pursue licensure as a professional surveyor in the state of Kentucky (26.0 credit hours) must also complete the requirements as listed below.

AMS 163	Architectural Drafting	3.0 Credit hours
CE 160	Principles of Surveying	3.0
CE 161	Principles of Surveying Lab	1.0
CE 378	Route Surveying	3.0
CE 379	Route Surveying Lab	1.0
CE 380	Boundary Surveying	3.0
CE 381	Boundary Surveying Lab	1.0
GEOG 316	Fundamentals of GIS	4.0
GEOG 318	GIS for Engineers <sup>†</sup>	3.0
GEOG 414	Remote Sensing Fundamentals	<u>4.0</u>

**TOTAL HOURS:                    26.0**

<sup>†</sup>GEOG 318 Geographic Information Systems (3 hours) can be taken instead of GEOG 317 Geographic Information Systems for Engineers.

### Prerequisite Flowchart of Required Courses

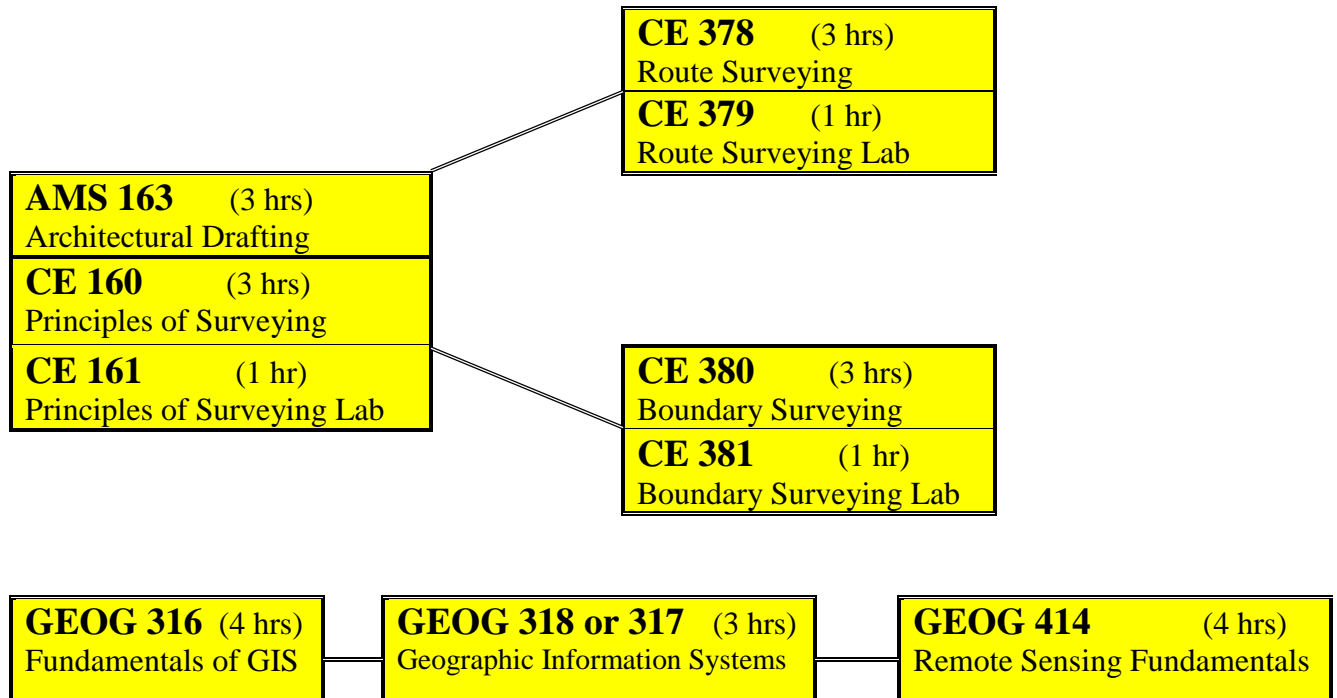

## FLOODPLAIN MANAGEMENT PROGRAM

The minor consists of a minimum of 21 hours including 13 hours of required courses including hydrology, surveying, Geographic Information Systems (GIS), and floodplain management. The 8 hours of electives may be selected from courses in meteorology, hydraulics, geographic information systems, geomorphology, and advanced surveying. Students successfully completing the minor may choose to become nationally certified floodplain managers. This is a joint program of the Engineering and Geology/Geography Departments.

***For more information contact:***

Warren Campbell, Ph.D., P.E., C.F.M.  
Hall Professor of Civil Engineering  
Associate Professor  
Department of Engineering  
Western Kentucky University  
270-745-8988  
[warren.campbell@wku.edu](mailto:warren.campbell@wku.edu)

## MINOR IN FLOODPLAIN MANAGEMENT REQUIREMENTS

### Required Courses (13 semester hours):

CE 160/161	Principles of Surveying and Lab	4.0 Credit hours
CE 300	Floodplain Management	3.0
GEOG 318	GIS for Engineers <sup>†</sup>	3.0
Choose one (1) of the following courses:		
CE 461	Hydrology	3.0
GEOG 310	Global Hydrology	3.0

<sup>†</sup>Geography or geology students can substitute GEOG 317 for GEOG 318.

### Elective Courses (Choose at least 8 semester hours):

GEOG 121	Meteorology	3.0 Credit hours
GEOG 207	Hurricanes	1.0
GEOG 208	Floods and Droughts	1.0
GEOG 209	Natural Disasters	1.0
GEOG 391	Data analysis and Interpretation	3.0
GEOG 414	Introduction to Remote Sensing	4.0
GEOG 416	Remote Sensing	3.0
GEOG 417	GIS Analysis and Modeling	3.0
GEOG 419	GIS Application Development	3.0
GEOG 420	Geomorphology	4.0
GEOG 422	Physical Climatology	4.0
GEOG 424	Weather Analysis and Forecasting	3.0
GEOG 426	Applied Meteorology/Climatology	3.0
GEOG 427	Water Resources	3.0
GEOG 431	Dynamic Meteorology	3.0
GEOL 445	Aqueous Geochemistry	3.0
GEOG 455	Global Environment Change	3.0
GEOG 474	Environmental Planning	3.0
GEOG 477	Special Topics in Geographic Information Systems <sup>†</sup>	3.0
CE 351 or 352	Introduction to Environmental Engineering	3.0
CE 378/379	Route Surveying and Lab	4.0
CE 380/381	Boundary Surveying and Lab	4.0
CE 462	Hydraulic Engineering Systems	3.0

<sup>†</sup>Requires project in floodplain related area

**Note: At least 6 hours must be taken outside the major.**

# CIVIL ENGINEERING ADVISING WORKSHEET (OPTION 1)

**Student NAME:**

**Student ID:**

Courses in CE Major	Course Title	Cr. Hrs.	Taken	Trans.	UK	Grade
ENGR 175	University Experience – Engineering	1				
CE 176	Civil Engineering Freshman Design	1				
CE 160	Principles of Surveying	3				
CE 161	Principles of Surveying Lab	1				
CE 303	Construction Management	3				
CE 304	Construction Management Lab	1				
CE 310	Strengths of Materials Lab	1				
CE 316	Equipment & Methods	3				
CE 331	Transportation Engineering	3				
CE 341 or CE 342	Fluid and Thermal Science	4				
CE 351 or 352	Introduction to Environmental Engineering	3				
CE 370/371	Materials of Construction and Lab	2/1				
CE 382 or CE 373	Structural Analysis	3				
CE 384 or ____	Reinforced Concrete Design	3				
CE 410	Soil Mechanics	3				
CE 411	Soil Mechanics Lab	1				
CE 412	Foundation Engineering	3				
CE 461	Hydrology	3				
CE 400	Senior Project Seminar	1				
CE 498	Senior Project	3				
CE ____	CE Technical Elective	3				
CE ____	CE Technical Elective	3				
CE ____	CE Technical Elective	3				
AMS 163	Architectural Drafting	3				
EM 221 or EM 222	Statics	3				
EM 302 or EM 303	Mechanics of Deformable Solids	3				
Section Sum		65		Sum		

**Math and Science**

MATH 136	Calculus I	4				
MATH 137	Calculus II	4				
MATH 237	Multivariable Calculus	4				
MATH 331	Differential Equations	3				
STAT 301	Probability and Applied Statistics	3				
CHEM 120	College Chemistry I	4				
CHEM 121	College Chemistry I Lab	1				
GEOL 111	The Earth	3				
GEOL 113	The Earth Lab	1				
PHYS 255	University Physics I	4				
PHYS 256	University Physics I Lab	1				
PHYS 265	University Physics II	4				
PHYS 266	University Physics II Lab	1				
Section Sum		37				

**General Education**

A.1 ENG 100	Freshman English	3				
A. 1 ENG 300		3				
A.2 Foreign Language (102)		3				
A.3 COMM 161 or 145	Business/Prof. Speaking	3				
B.1 ENG 200	Introduction to Literature	3				
B.2 Elective		3				
B.2 Elective		3				
C. HIST 119 or 120	Western Civilization: Before/After 1648	3				
C. ECON 202	Economics (Micro)	3				
C. Elective		3				
E. Elective		3				
F. Elective		1				
F. Elective		1				
Section Sum		35				

**CIVIL ENGINEERING ADVISING WORKSHEET (OPTION 2)****Student NAME:****Student ID:**

SEMESTER 1	COURSE	CR	GR	UK	SEMESTER 2	COURSE	CR	GR	UK
ENGR 175	Univ Exp - ENGR	1			CE 160	Surveying	3		
CE 176	CE Freshman Design	1			CE 161	Surveying Lab	1		
AMS 163	Architectural Drafting	3			MATH 137	Calculus II	4		
MATH 136	Calculus I	4			PHYS 255	Physics I	4		
GEOL 111	The Earth	3			PHYS 256	Physics I Lab	1		
GEOL 113	The Earth Lab	1			ENG 100	Freshman English	3		
Category E	World Cultures Elect	3			COM161or145	Public Speaking	3		

**16****19**

SEMESTER 3	COURSE	CR	GR	UK	SEMESTER 4	COURSE	CR	GR	UK
CE 303	Constr Mgmt	3			EM 302 or 303	Mech of Def Solids	3		
CE 304	Constr Mgmt Lab	1			CE 310	Str of Materials Lab	1		
EM 221 or 222	Statics	3			MATH 331	Differential. Eqs	3		
MATH 237	Multivariable Calculus	4			PHYS 265	Physics II	4		
CHEM 120	Chemistry I	4			PHYS 266	Physics II Lab	1		
CHEM 121	Chemistry I Lab	1			Category A-II	Foreign Lang (102)	3		
Category F	Health & Well Elect	1			ENG 200	Intro to Literature	3		

**17****18**

SEMESTER 5	COURSE	CR	GR	UK	SEMESTER 6	COURSE	CR	GR	UK
CE 382 or 373	Structural Analysis	3			CE 316	Equip and Methods	3		
CE 410	Soil Mechanics	3			CE 331	Transportation Eng	3		
CE 411	Soil Mechanics Lab	1			ENG 300	Junior English	3		
CE 341	Fluid & Thermal Sc	4			CE 412	Foundation Eng	3		
CE 370	Matls of Constr	2			CE 384	Reinf Conc Design <sup>1</sup>	3		
CE 371	Matls of Constr Lab	1			CE	Technical Elective <sup>2</sup>	3		
STAT 301	Prob and Statistics	3							
Category F	Health & Well Elect	1							

**18****18**

SEMESTER 7	COURSE	CR	GR	UK	SEMESTER 8	COURSE	CR	GR	UK
CE 351 or 352	Environmental Eng	3			CE 461	Hydrology	3		
CE	Technical Elective <sup>2</sup>	3			CE	Technical Elective <sup>2</sup>	3		
CE 400	Sr Design Seminar	3			CE 498	Senior Project	3		
ECON 202	Economics (Micro)	3			Category B-II	Humanities Elect	3		
HIST119 or 120	Western Civilization	3			Category C	Soc & Beh Sc Elect	3		
Category B-II	Humanities Elect	3							

**16****15****TOTAL HOURS = 137****Each student needs at least 16 cr. hrs. in major from UK faculty.****NOTES:**

1. Instead of CE 384 Reinforced Concrete Design, students may take CE 482 Elementary Structural Design or CE 483 UK-Elementary Structural Design if offered.
2. A two (2) course sequence in 4 different civil engineering areas is required. The curriculum already includes a two (2) course sequence in structures, geotechnical engineering, and construction. Therefore, each student must select one of their technical electives to cover an additional area such as surveying, materials, environmental engineering, hydrology, or transportation. See "TWO (2) COURSE SEQUENCE REQUIREMENT."

## ACADEMIC STANDARDS APPEAL FORM

The policies and standards associated with degree completion for graduation are described in this handbook, CE Student Handbook, with the latest version available on the program web page at [www.wku.edu/engineering](http://www.wku.edu/engineering). Please review them carefully before filing an appeal to a stated requirement.

A student who wishes to appeal a grade requirement of the program as outlined in the standards must use the following appeal process:

- After discussions with the faculty advisor, the student must sign and complete this form.
- The faculty advisor will present this form to the CE Program Faculty.
- If approved by the CE Program Faculty, then the faculty advisor and the CE Program Coordinator will sign the form and submit to Department Head and Dean for approval.
- The student will be informed of approval or denial of the appeal.
- This form will be sent to the Registrar's office upon approval, and a copy placed in the student's file in the Engineering Office.

Student Name \_\_\_\_\_ Student ID \_\_\_\_\_

Course Number	Semester Taken	Grade	Reason for Appeal

Other: \_\_\_\_\_

Student Signature: \_\_\_\_\_

Date: \_\_\_\_\_

CE Program Faculty Response to Appeal and Recommendations:

Faculty Advisor: \_\_\_\_\_

Date: \_\_\_\_\_

CE Program Coordinator: \_\_\_\_\_

Date: \_\_\_\_\_

Department Head: \_\_\_\_\_

Date: \_\_\_\_\_

Dean: \_\_\_\_\_

Date: \_\_\_\_\_